

# Vibration Isolation for **Staircases and Landings**

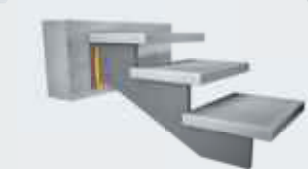

# Elastic Solutions for Staircases and Landings

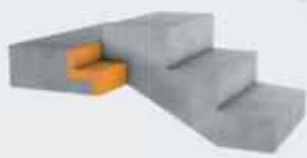
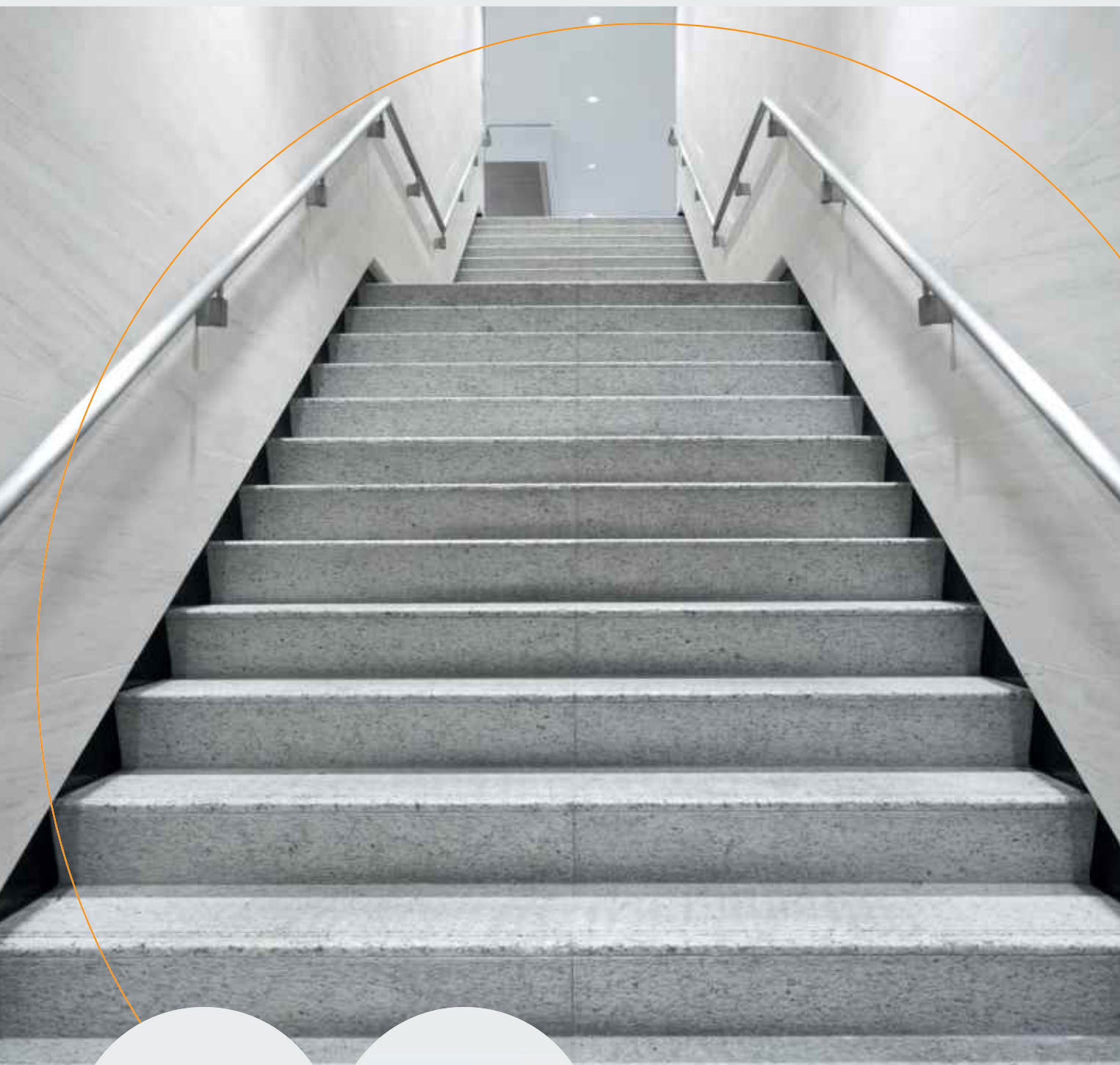

The Sylomer® SB10 bearing for stairs effectively decouples concrete stairs



Impact noise reduction 31 dB

## Concrete stairs

**Getzner solutions made from Sylomer® effectively decouple concrete and lightweight stairs, ensuring greater peace and quiet.**

People make noise when walking in buildings, which can be transmitted to adjacent rooms as structure-borne noise. Stairs in particular are frequent sources of noise. The elastic decoupling of flights of stairs and landings significantly reduces the transmission of structure-borne noise to nearby rooms via adjacent walls and ceilings, resulting in a reduction in the overall noise level in the building.

The Getzner SB10 bearing for concrete stairs is a combination of a Sylomer® strip and foam.

### Advantages

- Solutions for in-situ concrete and precast concrete stairs
- Outstanding impact noise reduction (31dB) at minimal installation height
- Quick and easy installation thanks to flexible design
- Compensation of construction tolerances
- Accurate load transmission and low deflection

### Details

To avoid sound bridges, the stair flight must be completely separated from the support structure.

### Installation and delivery dimensions

The Sylomer® SB10 bearing is delivered in stripes of 1.5 m. Thanks to the flexible product design, it can be easily adapted to the on-site requirements. A clean and even surface as well as the implementation of the joint between the concrete stair and support structure are especially important to guarantee effectiveness.

## Elastically mounted flight of stairs

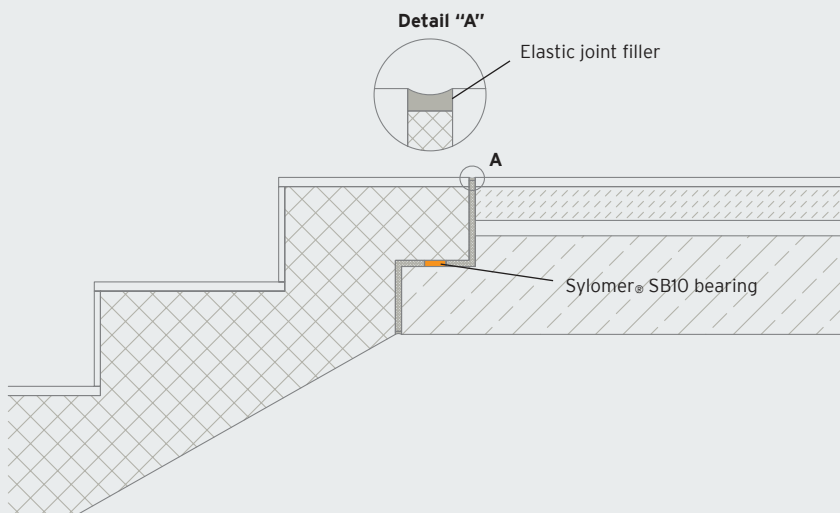



Decoupled harp staircase as skeleton structure



Elements made from Sylomer® guarantee greater peace and quiet

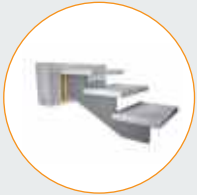

## Lightweight stairs

Elements made from Sylomer® decouple lightweight stairs from the support structure.

### Advantages

- Solutions for common lightweight stair designs
- Proven impact noise reduction of 29 dB
- Decoupling of low frequency ranges, even below 100 Hz
- Simple type selection
- Sustainable damping efficiency due to the excellent long-term behaviour of Sylomer®

### Details

Connections to walls and ceilings must also be decoupled. Getzner offers suitable detailed solutions for this purpose.

### Installation and delivery dimensions

Decoupling elements made from Sylomer® are available in different dimensions and can be installed both on-site and on the stairs prior to installation of the staircase. Screw-fixings on the stairs should also be decoupled using elastic washers in order to prevent sound bridges.



### Staircase connection

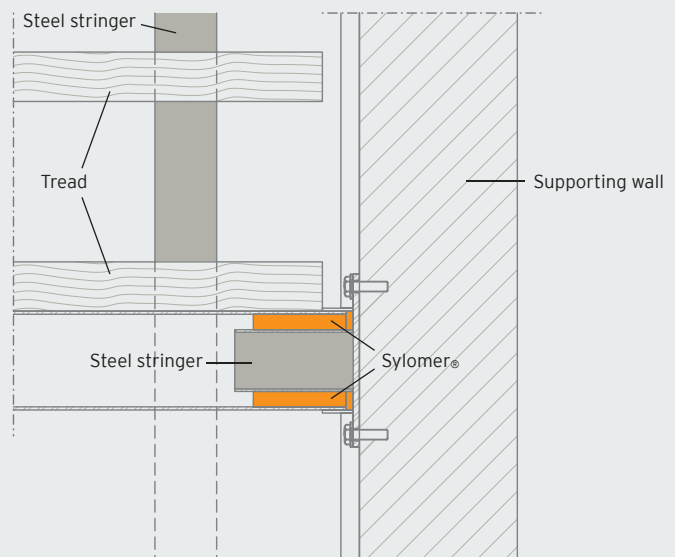



## Tests

All stair bearings from Getzner have been successfully tested with regard to their effectiveness on modern test rigs for stairs and with on-site measurements. In addition, Sylomer® bearings have already been successfully mounted on staircases for over three decades, with more stringent requirements on impact noise protection being met even under the most challenging conditions.

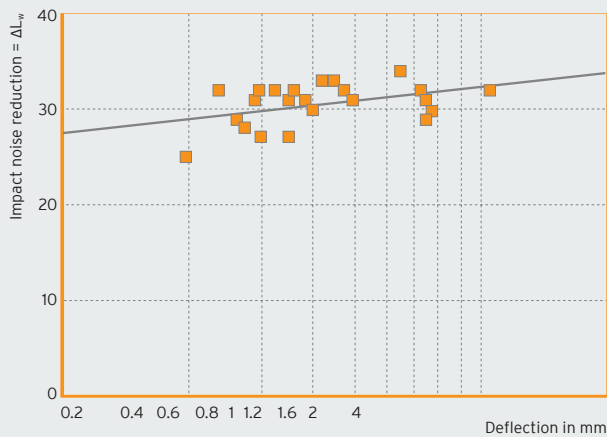

Representation of the reduction in impact noise using Sylomer® bearings based on measurements.

### External sound measurements taken by:

- Fraunhofer Institute for Building Physics, Stuttgart
- Testing and Research Institute of Magistrate District 39, Vienna
- Schalltechnisches Treppen-, Entwicklungs- und Prüfinstitut (Institute for the Acoustic Optimisation, Development and Testing of Stairs), Winnenden

## Construction references (extract)

- Terraced complex, Peralohstraße, Munich (DE), 2016
- Calanda industrial estate, Landquart (CH), 2016
- Terraced complex, Penzberg (DE), 2016
- Terraced complex, Germering (DE), 2016
- Retirement home, Augarten, Vienna (AT), 2015
- Hummelkaserne complex, Graz (AT), 2015
- JUFA Hotel Resort, Malbun (FL), 2015
- Semi-detached house, Anzing (DE), 2015
- Residential complex, Waldmühle Rodaun, Vienna (AT), 2014
- Residential complex, Breitenfurter Straße, Vienna (AT), 2014
- Luxury apartments, Abtwil (CH), 2014
- Terraced complex, Rimsting (DE), 2014



Find out more at  
[www.getzner.com/stairs](http://www.getzner.com/stairs)